



AEROFLOW SUPPLEMENT

Special “Live Loaded” Packing Arrangement

TABLE OF CONTENTS

INSTALLATION.....	1
MAINTENANCE.....	1
PACKING ADJUSTMENT.....	1
ILLUSTRATION INDEX	
FIGURE 1- LIVE LOADED PACKING ARRANGEMENT	1

INSTALLATION

CAUTION!

All warnings from valve IOM must be followed.

NOTE: Refer to Fig. 1 for installation.

1. Thread packing studs (5) into valve bonnet.
2. With the packing follower and packing installed (refer to valve IOM) install packing flange (1) onto valve as shown.
3. Install spring washer (2) as shown on the left side of Fig. 1 in series.
4. Install spring spacer (3), washer (4) and packing nut (6) as shown.
5. Tighten the packing nut (6) until the washer (4) comes into contact with top of the packing flange (1). This will set the live loaded packing to the required thrust.

Maintenance

PACKING ADJUSTMENT

1. Once valve has been placed in service, and the valve has been cycled to pressure/temperature, the packing nuts (4) may need to be readjusted (when the valve is depressurized and cools to ambient). This is due to “new” packing taking a set when cycled in service.
2. All other packing maintenance, inspection, and cleaning should follow the guidelines set forth in the valve IOM.

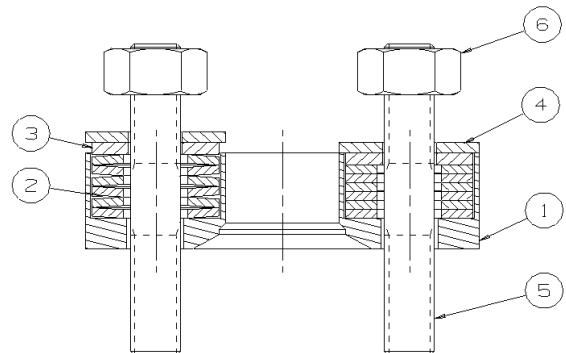

Figure 1- Live Loaded Packing Arrangement